



REGIONAL DISTRICT OF CENTRAL KOOTENAY

**AREA I ADVISORY PLANNING AND HERITAGE
COMMISSION
OPEN MEETING MINUTES**

6:30PM

Wednesday, April 15, 2026

Hybrid Meeting

To promote openness, transparency and provide accessibility to the public we provide the ability to attend all RDCK meetings in-person or remote.

Join by Video:

<https://rdck-bc-ca.zoom.us/j/98440624910?pwd=9JQyXil1Zannf7mif5hF90fAswn5qj.1>

Join by Phone:

1 778 907 2071 Canada

Meeting ID: 984 4062 4910

Passcode: 640628

Meeting Location:

Brilliant Cultural Centre – Youth Room

1875 Brilliant Road

Castlegar, BC

1. CALL TO ORDER

Director Davidoff called the meeting to order at ____ p.m

2. TRADITIONAL LANDS ACKNOWLEDGEMENT STATEMENT

We acknowledge and respect the Indigenous peoples within whose traditional lands we are meeting today.

3. ADOPTION OF AGENDA

MOVED and seconded,
AND Resolved:

The Agenda for the April 15, 2026 Electoral Area I Advisory Planning and Heritage Commission meeting, be adopted as circulated.

Carried/Defeated

4. RECEIPT OF MINUTES

The February 9, 2026 Electoral Area I Advisory Planning and Heritage Commission minutes, were received.

5. STAFF REPORTS

5.1 DEVELOPMENT VARIANCE PERMIT APPLICATION (V2605I) – Shane Aker

The Development Variance Application dated March 16, 2026, from Sadie Chezenko, Planner 1, was received.

Moved and seconded,
AND Resolved:

That the Area I Advisory Planning and Heritage Commission **SUPPORT/NOT SUPPORT** the Development Variance Permit Application to Shane Aker for the property located at 2250 Glade Road, Glade, LOT B DISTRICT LOT 302A KOOTENAY DISTRICT PLAN EPP81680.

Carried/Defeated

6. PUBLIC TIME

The Chair will call for questions from the public at ____ p.m.

7. NEXT MEETING

The next Electoral Area I Advisory Planning and Heritage Commission Meeting is scheduled for May 4, 2026.

ADJOURNMENT

MOVED and seconded,
AND Resolved:

The Electoral Area I Advisory Planning and Heritage Commission meeting be adjourned at ____ p.m.

Carried/Defeated



REGIONAL DISTRICT OF CENTRAL KOOTENAY

**AREA I ADVISORY PLANNING AND HERITAGE
COMMISSION
OPEN MEETING MINUTES**

6:30PM

Monday, February 9, 2026

Online Meeting

To promote openness, transparency and provide accessibility to the public we provide the ability to attend all RDCK meetings in-person or remote.

Join by Video:

<https://rdck-bc-ca.zoom.us/j/98440624910?pwd=9JQyXil1Zannf7mif5hF90fAswn5qj.1>

Join by Phone:

1 778 907 2071 Canada

Meeting ID: 984 4062 4910

Passcode: 640628

Meeting Location:

Online

COMMISSIONERS PRESENT

Commissioner Brian Bebelman	Electoral Area I, Chair
Commissioner Andy Ozeroff	Electoral Area I

COMMISSIONERS PRESENT

Commissioner Kelly Poznikoff	Electoral Area I
------------------------------	------------------

DIRECTOR

Director Andy Davidoff	Electoral Area I
------------------------	------------------

STAFF

Sadie Chezenko	Planner
Shelly Kindred	Meeting Coordinator

APPLICANTS

George Soukeroff	Stacy Johnston
------------------	----------------

2 out of 3 voting Commission members were present – quorum was met.

1. CALL TO ORDER

Director Davidoff called the meeting to order at 6:39 p.m.

2. TRADITIONAL LANDS ACKNOWLEDGEMENT STATEMENT

We acknowledge and respect the Indigenous peoples within whose traditional lands we are meeting today.

3. ADOPTION OF AGENDA

MOVED and seconded,
AND Resolved:

The Agenda for the February 9, 2026 Electoral Area I Advisory Planning and Heritage Commission meeting, be adopted as circulated.

Carried

4. RECEIPT OF MINUTES

The January 5, 2026 Electoral Area I Advisory Planning and Heritage Commission minutes, were received.

5. STAFF REPORTS

5.1 DEVELOPMENT VARIANCE PERMIT APPLICATION (V25071) – Stacy Johnston

The Development Variance Application dated December 1, 2025, from Sadie Chezenko, Planner 1, was received.

Planner Sadie Chezenko gave a brief overview of the application.

The Applicants shared their concerns, perspectives and intended use of the property for the proposed Development Variance Application.

The Applicants answered questions from both the Commission and Planner.

Staff expressed concerns for a newly created lot bisecting a legally dedicated road and water access for neighboring properties.

Director Davidoff thanked the applicants for attending and answering the Commission's questions.

Moved and seconded,
AND Resolved:

That the Area I Advisory Planning and Heritage Commission **SUPPORT** the Development Variance Permit Application to Stacy Johnston for the property located at 2270 Lower Gibson Road, Pass Creek LOT 2 DISTRICT LOT 7448 KOOTENAY DISTRICT PLAN NEP76618.

Carried

6. PUBLIC TIME

The Chair will call for questions from the public at 7:11 p.m.

7. NEXT MEETING

The next Electoral Area I Advisory Planning and Heritage Commission Meeting is scheduled for March 2, 2026.

ADJOURNMENT

MOVED and seconded,
AND Resolved:

The Electoral Area I Advisory Planning and Heritage Commission meeting be adjourned at 7:13 p.m.

Carried



Development Variance Permit Application

Referral Form – RDCK File V26051

Date: March 16, 2026

You are requested to comment on the attached DEVELOPMENT VARIANCE PERMIT for potential effect on your agency’s interests. We would appreciate your response WITHIN 30 DAYS (PRIOR TO APRIL 16, 2026). If no response is received within that time, it will be assumed that your agency’s interests are unaffected.

LEGAL DESCRIPTION & GENERAL LOCATION:

2250 Glade Road, Glade, Electoral Area ‘I’
 LOT B DISTRICT LOT 302A KOOTENAY DISTRICT PLAN EPP81680
 030-492-891

PRESENT USE AND PURPOSE OF PERMIT REQUESTED:

The property is presently being used for residential purposes and has been improved with a single detached dwelling and a 93m2 accessory building.

The accessory building was constructed without a valid building permit within the 2.5m side setback. The owner is seeking this variance to consider the accessory building to remain in this location. Due to the location of the existing residence, a variance to the farm residential footprint (FRF) regulations is also required.

Specifically, this Development Variance Permit (DVP) seeks to vary RDCK Zoning Bylaw No. 1675, 2004 as follows:

- 605(1) To reduce the required side setback from 2.5 metres to 1.3 metres, and;
- 2701(4) To allow a FRF depth of 90m whereas the bylaw requires a FRF depth of 60m.

AREA OF PROPERTY AFFECTED	ALR STATUS	ZONING	OCP
0.56 ha	yes	Agriculture 1 (AG1) in RDCK Zoning Bylaw No. 1675, 2004	Agriculture (AG) in Sentinel Mountain Official Community Plan Bylaw No. 2821, 2024

APPLICANT: Shane Aker

Please provide your response via email.

If your agency’s interests are ‘Unaffected’ no further information is necessary. In all other cases, we would appreciate receiving additional information to substantiate your position and, if necessary, outline any conditions related to your position. Please note any legislation or official government policy which would affect our consideration of this permit.

If you are an RDCK commission member, do not respond via email. Your response is the commission’s recommendation which staff will collect from the meeting minutes.

<input checked="" type="checkbox"/> MINISTRY OF TRANSPORTATION AND INFRASTRUCTURE <input checked="" type="checkbox"/> HABITAT BRANCH (Environment) <input checked="" type="checkbox"/> FRONTCOUNTER BC (MFLNRORD) <input checked="" type="checkbox"/> AGRICULTURAL LAND COMMISSION <input checked="" type="checkbox"/> REGIONAL AGROLOGIST <input checked="" type="checkbox"/> ARACHAEOLOGY BRANCH <input type="checkbox"/> ENERGY & MINES <input type="checkbox"/> MUNICIPAL AFFAIRS & HOUSING <input checked="" type="checkbox"/> INTERIOR HEALTH, HBE TEAM	REGIONAL DISTRICT OF CENTRAL KOOTENAY DIRECTORS FOR: <input type="checkbox"/> A <input type="checkbox"/> B <input type="checkbox"/> C <input type="checkbox"/> D <input type="checkbox"/> E <input type="checkbox"/> F <input type="checkbox"/> G <input type="checkbox"/> H <input checked="" type="checkbox"/> I <input type="checkbox"/> J <input type="checkbox"/> K ALTERNATIVE DIRECTORS FOR: <input type="checkbox"/> A <input type="checkbox"/> B <input type="checkbox"/> C <input type="checkbox"/> D <input type="checkbox"/> E <input type="checkbox"/> F <input type="checkbox"/> G <input type="checkbox"/> H <input type="checkbox"/> I <input type="checkbox"/> J <input type="checkbox"/> K <input checked="" type="checkbox"/> APHC AREA I <input checked="" type="checkbox"/> RDCK FIRE SERVICES <input checked="" type="checkbox"/> RDCK EMERGENCY SERVICES <input checked="" type="checkbox"/> RDCK BUILDING SERVICES <input type="checkbox"/> RDCK UTILITY SERVICES
---	--

<input type="checkbox"/> SCHOOL DISTRICT NO.	<input type="checkbox"/> RDCK RESOURCE RECOVERY
<input checked="" type="checkbox"/> WATER SYSTEM OR IRRIGATION DISTRICT	<input type="checkbox"/> RDCK REGIONAL PARKS
<input checked="" type="checkbox"/> UTILITIES (FORTIS, BC HYDRO, NELSON HYDRO, COLUMBIA POWER)	



The personal information on this form is being collected pursuant to *Regional District of Central Kootenay Planning Procedures and Fees Bylaw No. 2457, 2015* for the purpose of determining whether the application will affect the interests of other agencies or adjacent property owners. The collection, use and disclosure of personal information are subject to the provisions of FIPPA. Any submissions made are considered a public record for the purposes of this application. Only personal contact information will be removed. If you have any questions about the collection of your personal information, contact the Regional District Privacy Officer at 250.352.6665 (toll free 1.800.268.7325), info@rdck.bc.ca, or RDCK Privacy Officer, Box 590, 202 Lakeside Drive, Nelson, BC V1L 5R4.

RDCK Map



REGIONAL DISTRICT OF CENTRAL KOOTENAY
Box 590, 202 Lakeside Drive,
Nelson, BC V1L 5R4
Phone: 1-800-268-7325 www.rdck.bc.ca
maps@rdck.bc.ca

Legend

- Place Names
-  Electoral Areas
-  RDCK Streets
-  Cadastre - Property Lines

Map Scale:

1:18,056

Date: March 9, 2026



The mapping information shown are approximate representations and should only be used for reference purposes. The Regional District of Central Kootenay is not responsible for any errors or omissions on this map.

RDCK Map



REGIONAL DISTRICT OF CENTRAL KOOTENAY
 Box 590, 202 Lakeside Drive,
 Nelson, BC V1L 5R4
 Phone: 1-800-268-7325 www.rdck.bc.ca
 maps@rdck.bc.ca

Legend

- Electoral Areas
- RDCK Streets
- Cadastre - Property Lines
- Address Points

Map Scale:

1:4,514

Date: March 9, 2026







The mapping information shown are approximate representations and should only be used for reference purposes. The Regional District of Central Kootenay is not responsible for any errors or omissions on this map.

RDCK Map



REGIONAL DISTRICT OF CENTRAL KOOTENAY
Box 590, 202 Lakeside Drive,
Nelson, BC V1L 5R4
Phone: 1-800-268-7325 www.rdck.bc.ca
maps@rdck.bc.ca

Legend

-  Electoral Areas
-  RDCK Streets
-  Cadastre - Property Lines
-  Address Points

Map Scale:

1:2,257

Date: March 9, 2026



The mapping information shown are approximate representations and should only be used for reference purposes. The Regional District of Central Kootenay is not responsible for any errors or omissions on this map.

RDCK Map



REGIONAL DISTRICT OF CENTRAL KOOTENAY
 Box 590, 202 Lakeside Drive,
 Nelson, BC V1L 5R4
 Phone: 1-800-268-7325 www.rdck.bc.ca
 maps@rdck.bc.ca

Legend

- Electoral Areas
- RDCK Streets
- Cadastre - Property Lines
- Agriculture
- Environmental Reserve
- Address Points

Official Community Plan

Map Scale:

1:2,257

Date: March 9, 2026



The mapping information shown are approximate representations and should only be used for reference purposes. The Regional District of Central Kootenay is not responsible for any errors or omissions on this map.

RDCK Map



REGIONAL DISTRICT OF CENTRAL KOOTENAY
Box 590, 202 Lakeside Drive,
Nelson, BC V1L 5R4
Phone: 1-800-268-7325 www.rdck.bc.ca
maps@rdck.bc.ca

Legend

Zoning Class

- Agriculture
- Electoral Areas

- RDCK Streets
- Cadastre - Property Lines
- Address Points

Map Scale:

1:2,257

Date: March 9, 2026



The mapping information shown are approximate representations and should only be used for reference purposes. The Regional District of Central Kootenay is not responsible for any errors or omissions on this map.

RDCK Map







Vantor



REGIONAL DISTRICT OF CENTRAL KOOTENAY
Box 590, 202 Lakeside Drive,
Nelson, BC V1L 5R4
Phone: 1-800-268-7325 www.rdck.bc.ca
maps@rdck.bc.ca

Legend

-  Agriculture Land Reserve
-  Electoral Areas
-  RDCK Streets
-  Cadastre - Property Lines
-  Address Points

Map Scale:

1:2,257

Date: March 9, 2026



The mapping information shown are approximate representations and should only be used for reference purposes. The Regional District of Central Kootenay is not responsible for any errors or omissions on this map.

RDCK Map



Vantor



REGIONAL DISTRICT OF CENTRAL KOOTENAY
Box 590, 202 Lakeside Drive,
Nelson, BC V1L 5R4
Phone: 1-800-268-7325 www.rdck.bc.ca
maps@rdck.bc.ca

Development Permit Areas

- Watercourse
- Wildfire

Legend

- Electoral Areas
- RDCK Streets
- Cadastre - Property Lines
- Address Points

Map Scale:

1:2,257

Date: March 9, 2026



The mapping information shown are approximate representations and should only be used for reference purposes. The Regional District of Central Kootenay is not responsible for any errors or omissions on this map.

Setback Requirements

605

- 1 Unless otherwise stated, no principal or accessory building or structure except a fence may be located within 7.5 metres of a front or exterior side lot line or within 2.5 metres of any other lot line.

Development Regulations

2701

1. The minimum lot size shall be 4.0 hectares in the Agricultural Land Reserve and 2.0 hectares outside the Agricultural Land Reserve.
- 1B. The maximum density is 2 Dwelling Units.
2. The maximum site coverage permitted shall be 35 percent of the lot area

Regional District of Central Kootenay Zoning Bylaw No. 1675, 2004 (Consolidated Version)
Page 99 of 155

unless an area not larger than 60 percent of the lot is covered with greenhouses.

3. The maximum Farm Residential Footprint shall be a maximum of 2000 square meters where one dwelling unit is permitted plus 500 square meters per additional permitted dwelling unit.
4. The maximum depth of the Farm Residential Footprint shall not exceed 60.0 metres measured from the Front Lot Line or Exterior Side Lot Line.

NW

154 1/4 N

NE

SHT METAL ROOFING
15# FELT OYEN
2x4 STRAPPING 20" o/c

2 16" x 3/8 GRK
TIMBER SCREWS PER POST TO BEAM

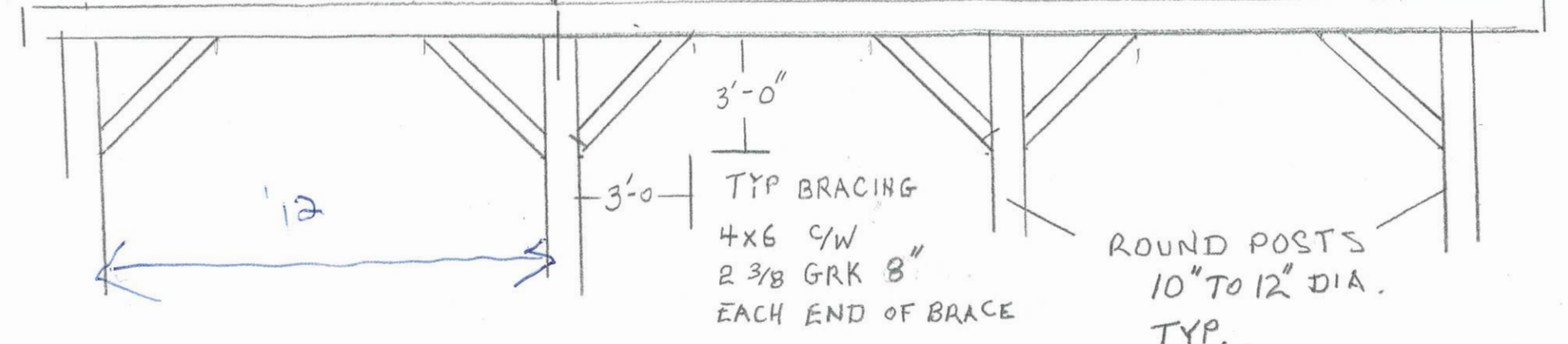
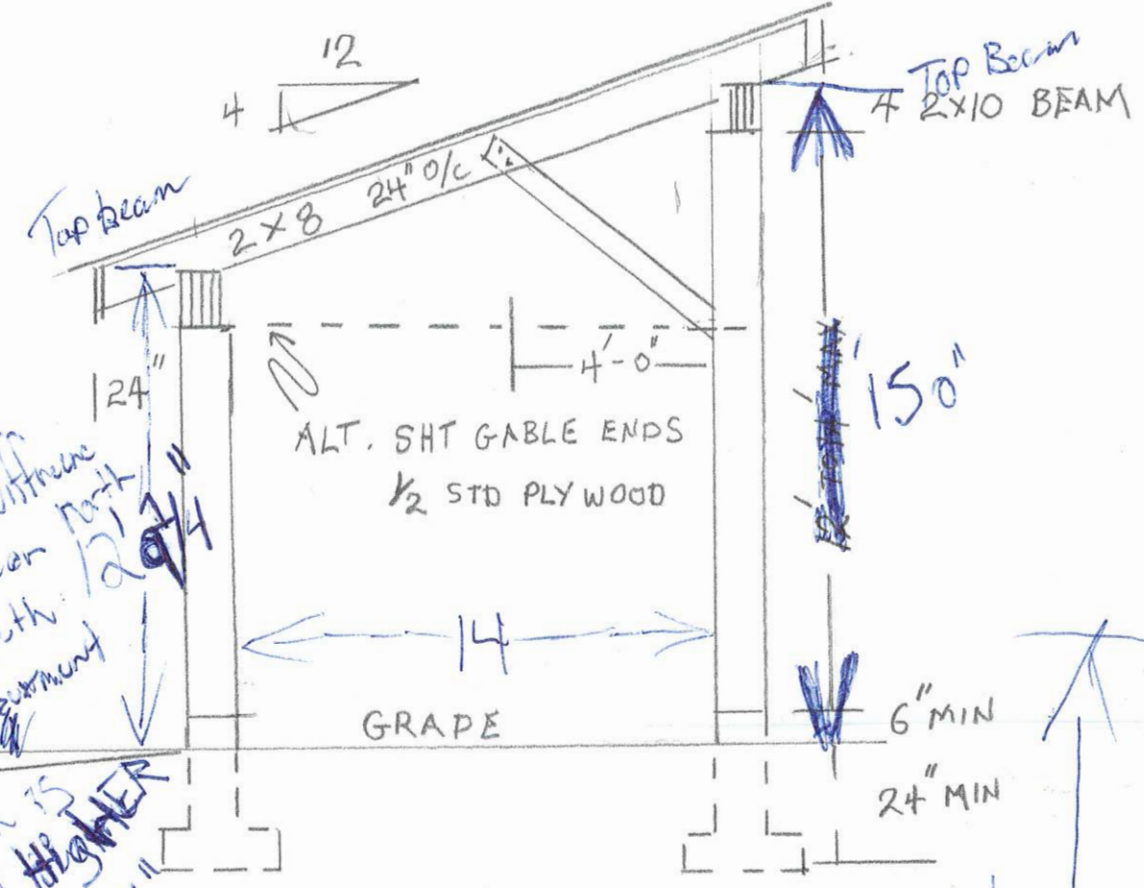

FRONT VIEW

2" diff
Between
N South
measurement

North is
1" higher
@ 12' 10 1/4"

Still have to cut
1/2" off NW post

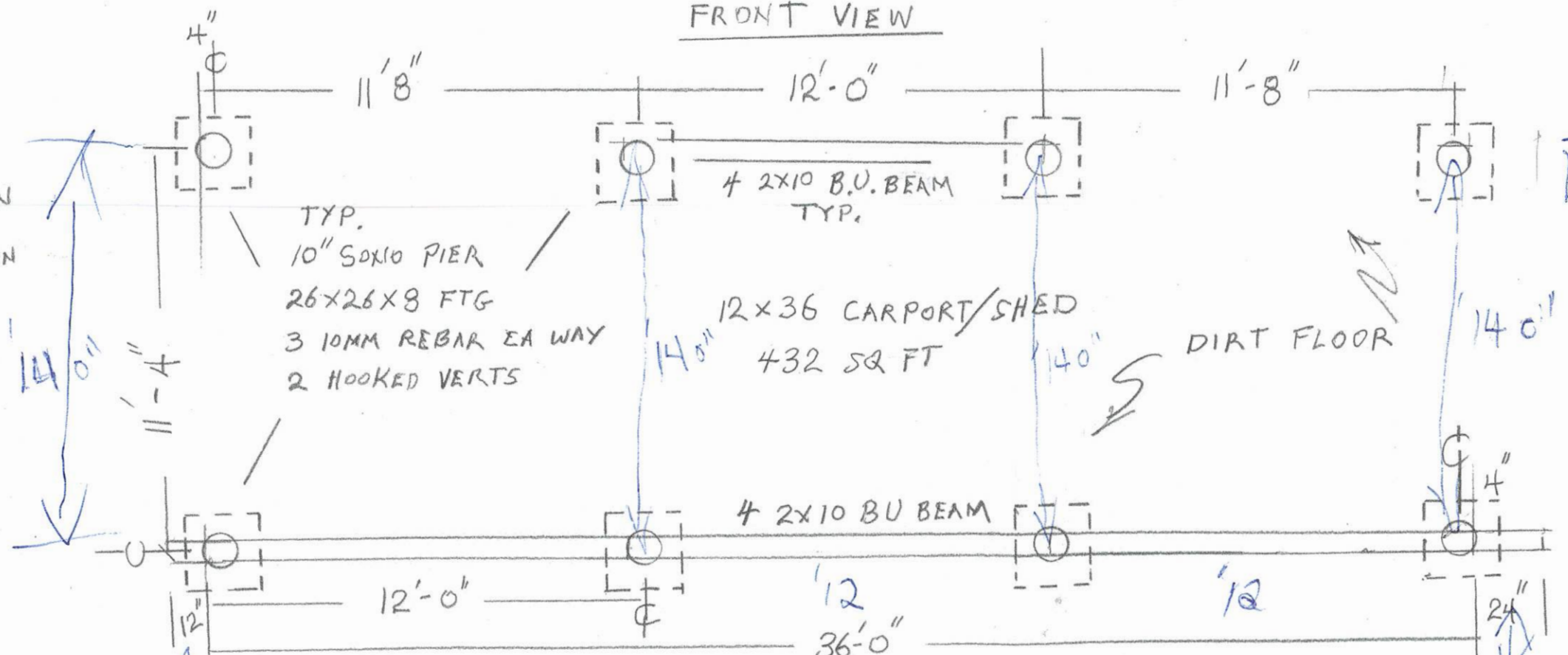

PLAN VIEW

BOTTOM OF POST DETAIL
1/4 x 1/2 FLAT BAR 20"
2 1/2 x 12 CARAGE BOLTS
THROUGH POSTS TYP.

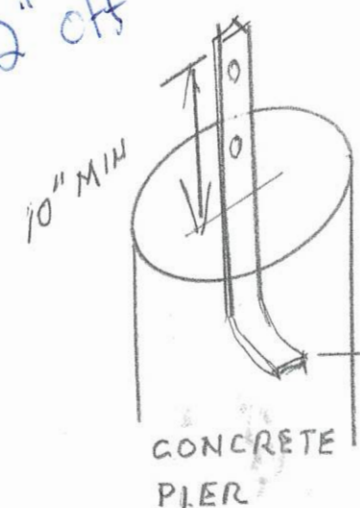

14 2x10
12

roof
S 2/12

SHANE ACKER	
TRACTOR SHED	
JULY 28 2024	1/4" = 1'-0"

SW

SE

SHT METAL ROOFING
 15# FELT OVER
 2x4 STRAPPING 20" O/C

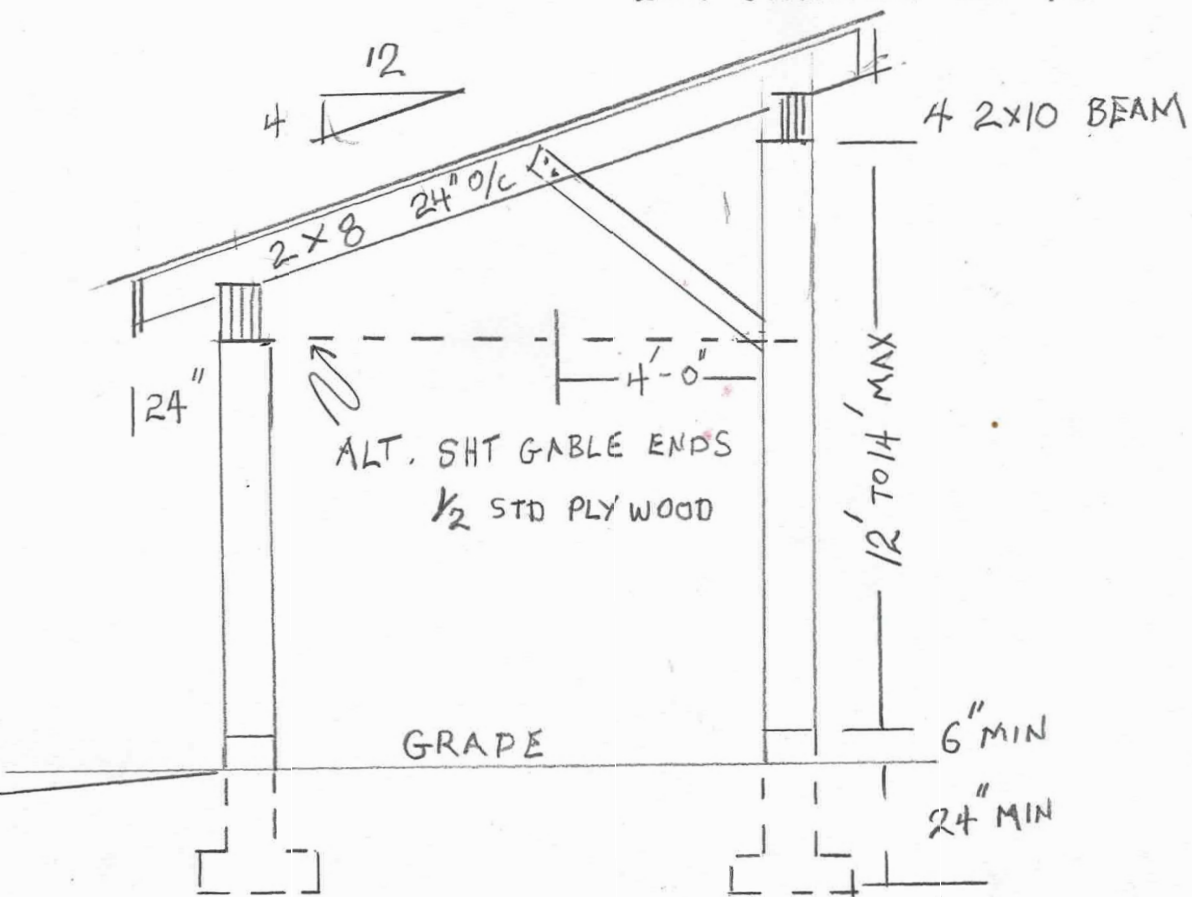

END VIEW

BOTTOM OF POST DETAIL
 1/4 x 1/2 FLAT BAR 20"
 2 1/2 x 12 CARAGE BOLTS
 THROUGH POSTS TYP.

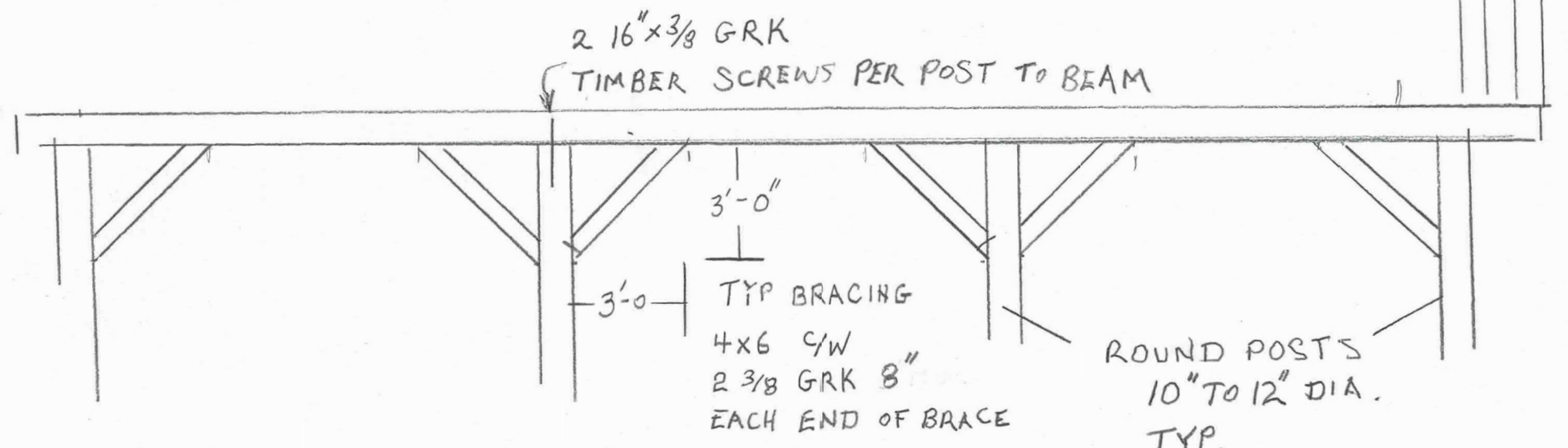
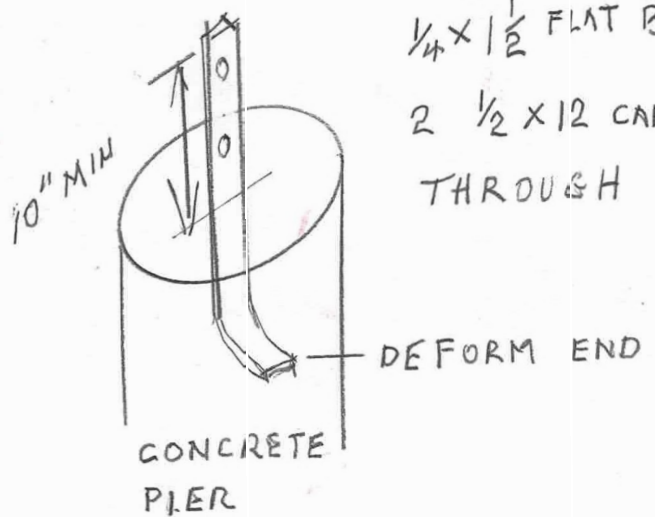

FRONT VIEW

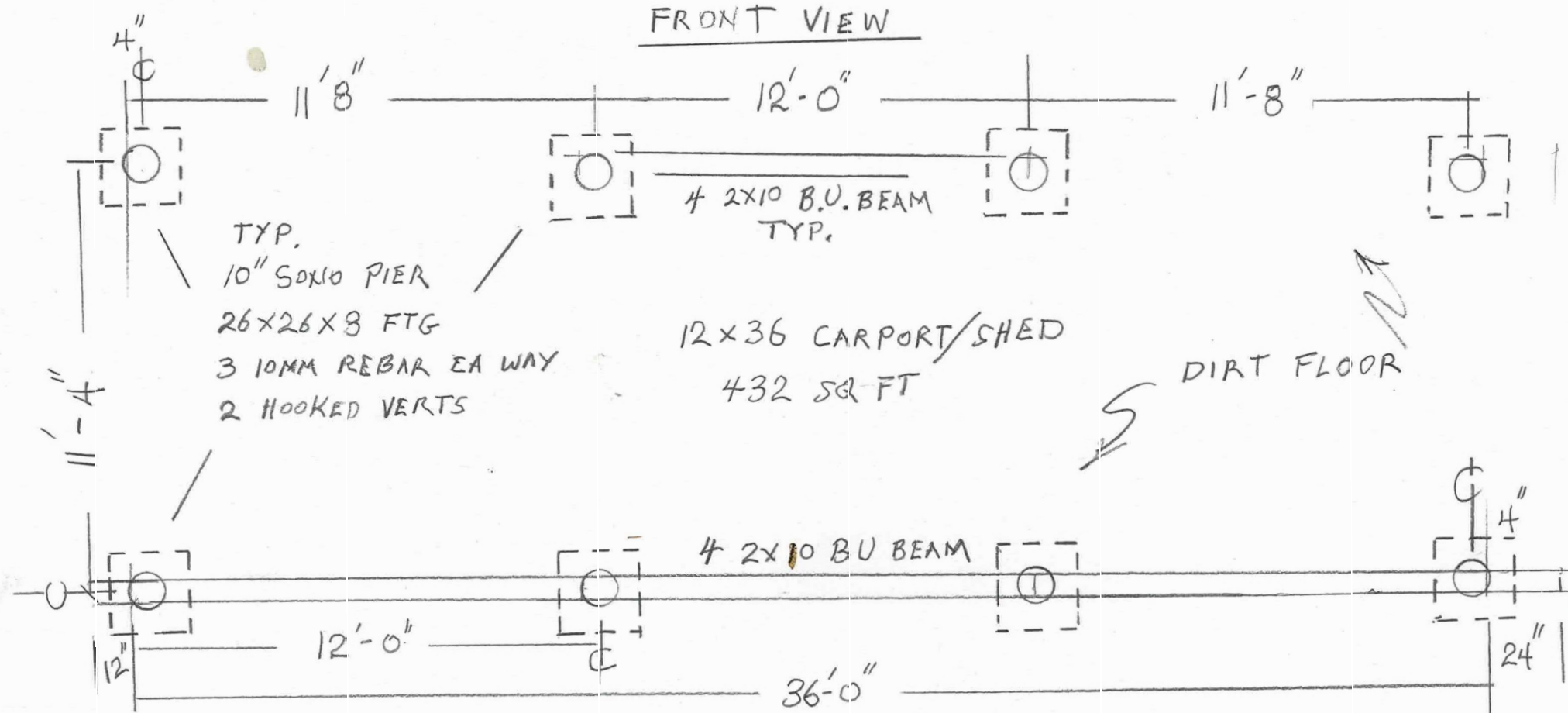

PLAN VIEW

SHANE ACKER	
TRACTOR SHED	
JULY 28 2024	1/4" = 1'-0"



RDCK Map

Legend

- Electoral Areas
- RDCK Streets
- Cadastre - Property Lines
- Address Points



Map Scale:

1:1,128



Date:

March 12, 2026

REGIONAL DISTRICT
OF CENTRAL KOOTENAY
Box 590, 202 Lakeside Drive,
Nelson, BC V1L 5R4
Phone: 1-800-268-7325
www.rdck.bc.ca
maps@rdck.bc.ca

The mapping information shown are approximate representations and should be used for reference purposes only. The Regional District of Central Kootenay is not responsible for any errors or omissions on this map.